

Gebrauchsanleitung PK-Nr. 3429
Instructions / Mode d'emploi / Gebruiksaanwijzing /
инструкция по использованию / 使用说明 / Használati utasítás

PAIDI Möbel GmbH
Hauptstraße 87
97840 Hafenlohr
Germany

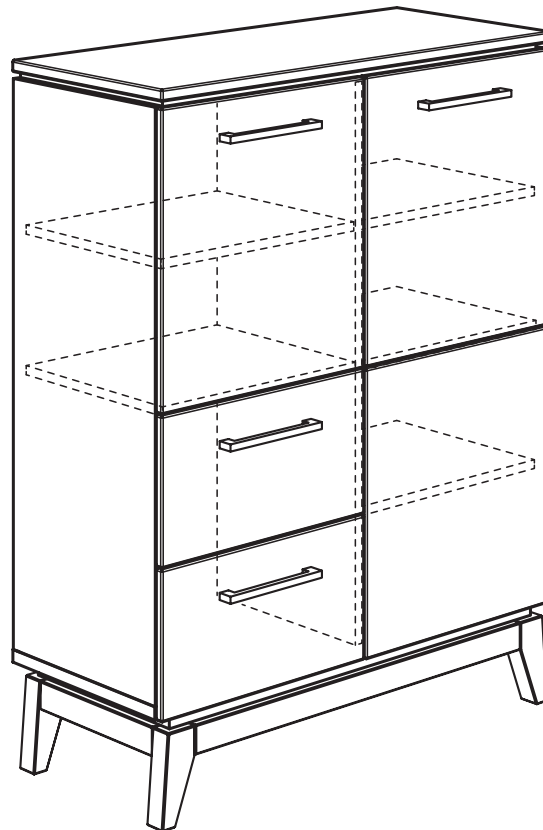

Kinderwelten



STIENE
127 5582



www.blauer-engel.de/uz38

- emissionsarm
- Holz aus nachhaltiger Forstwirtschaft





Warnhinweis!

Warning! / Avertissement! / Waarschuwing! / Предупреждение! / 警告! / Figyelmeztetés



PAIDI Möbel GmbH
Hauptstraße 87
97840 Hafenhöhr
Germany



Kinderwelten

V..

Vorbereitung / Preparation /
Préparation / Voorbereiding /
Подготовка / 准备 / Előkészítés

M..

Montage / Assembly /
Assemblage / Montage / Монтаж /
组装 / Összeszerelés

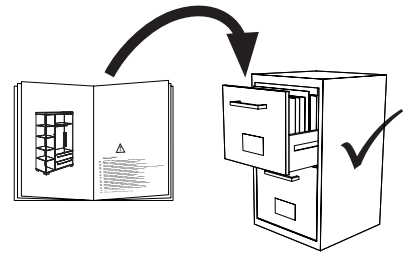

PK-Nr. 2800



Warnhinweis!

- DE Warnhinweis! Beiliegende Wandbefestigungen müssen montiert werden!**
- FR** Attention! Les fixations murales ci-jointes doivent être montées!
- GB** Attention! The enclosed wall mountings must be fitted!
- NL** Let op! De meegeleverde wandbevestigingen moeten worden gemonteerd!
- ES** ¡Atención! Las fijaciones murales incluidas deben montarse!
- GR** Προσοχή! Τα εξαρτήματα στήριξης που περιλαμβάνονται στη συσκευασία πρέπει να συναρμολογηθούν!
- IT** Attenzione! Occorre montare i fissaggi per attacco alla parete qui allegati!
- CZ** Pozor! Přiložené úchytky musí být namontovány na stěnu!
- SL** Pozor! Namontirati je potrebno priložene elemente za pritrditev na zid!
- PL** Uwaga! Załączzone zamocowania do ściany muszą być zamontowane!
- BG** Внимание! Приложените закрепвания за стена трябва да бъдат монтирани!
- HR** Pozor! Priložena zidna pričvršćenja moraju biti montirana!
- LT** Dėmesio! Pridedamas tvirtinimo prie sienos detales reikia sumontuoti!
- RU** Внимание! Обязательно используйте прилагаемые крепления стене!
- CN** 注意! 附带的墙壁安装组件必须安装!
- HU** Figyelem! A mellékelt fall rögzítőket össze kell szerelni!
- AR** تنبيه! لا بد من تركيب الأدوات المرفقة للتثبيت على الحائط!
- DE** **Schraubenverbindungen von Zeit zu Zeit auf ihre Festigkeit prüfen, gegebenenfalls nachziehen, da die Stabilität der Konstruktion sonst nicht gegeben ist.**
- FR** Vérifier les connexions à vis de temps en temps, resserrer celles-ci le cas échéant, car, sinon, la stabilité de la construction ne serait pas assurée.
- GB** Check the tightness of the screw connections from time to time and tighten if necessary, as otherwise the stability of the construction is not assured.
- NL** Schroefverbindingen moeten van tijd tot tijd op hun stevigheid worden gecontroleerd en eventueel worden vastgedraaid, aangezien de stabiliteit van de constructie anders niet verzekerd is.
- ES** Compruebe de vez en cuando la firmeza de las uniones atornilladas y reapriete los tornillos si fuera necesario, pues de lo contrario quedaría afectada la estabilidad de la estructura.
- GR** Πού και πού ελέγχετε τη σταθερότητα των κοχλιωτών συνδέσεων κι εφ' όσον είναι ανάγκη, τις σφίγγετε ξανά, επειδή διαφορετικά δεν είναι η ευστάθεια της κατασκευής δεδομένη.
- IT** Controllare di tanto in tanto la tenuta delle connessioni a viti, all'occorrenza provvedere a serrarle di nuovo, poiché altrimenti non è garantita la stabilità della struttura.
- CZ** Čas od času zkontrolujte pevnost šroubových spojů, případně je dotáhněte, jinak nebude konstrukce stabilní.
- SL** Vijačne zveze od časa do časa preveriti glede na trdnost, po potrebi priviti, saj sicer stabilnost konstrukcije ne bo zagotovljena.
- PL** Połączenia śrubami sprawdzać od czasu do czasu pod kątem ich trwałości, ewentualnie dokręcać, gdyż inaczej konstrukcja nie jest stabilna.
- BG** Контролирайте от време на време дали болтовите съединения са добре завинтени, тъй като в противен случай не може да се гарантира стабилността на конструкцията.
- HR** Spojeve vijaka s vremena na vrijeme provjeriti u svezi čvrstoće, po potrebi stegnuti, jer inače nije zajamčena stabilnost konstrukcije.
- LT** Kartais patikrinkite varžtų jungčių stiprumą, prireikus suvėžkite juos stipriau, nes priešingu atveju konstrukcija nebus stabilii.
- RU** Перепроверяйте время от времени болтовые соединения. Они должны быть плотно затянуты. Это гарантирует стабильность конструкции.
- CN** 请经常的检查连接处的螺丝，如有发现松动请及时锁紧，否则将无法保障其稳定性。
- HU** Időről ellenőrizze a csavarokétekek szorosságát, adott esetben a csavarokat után kell húzni, ellenkező esetben a szerkezet stabilitása nem adott.
- DE** **Pflegehinweis: Zum Reinigen der Oberflächen ein leicht-feuchtes Tuch oder ein handelsübliches Möbelpflegemittel verwenden.**
- FR** Indication sur l'entretien: pour nettoyer les surfaces, utiliser un chiffon légèrement humide ou un nettoyant pour meubles en vente dans le commerce
- GB** Caring for the...: In order to clean the surfaces please use a slightly damp cloth or commercially available furniture care product.
- NL** Verzorgingsanwijzing: Voor het reinigen van de oppervlakken een licht vochtig doek of een gebruikelijk meubelschoonmaakmiddel gebruiken.
- ES** Recomendaciones de cuidado: Para limpiar las superficies del mueble debe usar un trapo humedecido o un producto de limpieza de muebles comercial.
- GR** Οδηγίες περιποίησης: Για το καθάρισμα των επιφανειών να χρησιμοποιείτε ένα ελαφρά νοτισμένο πανάκι ή λούστρο επίπλων.
- IT** Indicazione per pulizia e cura: Per la pulizia delle superfici utilizzare un panno leggermente umido o un normale prodotto per la cura dei mobili.
- CZ** Pokyny k čištění: Na čištění povrchu použijte pouze navlhčený kousek látky nebo běžný prostředek na ošetřování nábytku.
- SL** Navodilo za nego: Za čiščenje površin uporabljajte malo vlažno čunjo ali trgovsko običajno sredstvo za nego pohištva.
- PL** Wskazówka pielęgnacyjna: do czyszczenia powierzchni stosować lekko wilgotną ściereczkę lub zwykły środek do pielęgnacji mebli.
- BG** Указания за поддържане: Използвайте леко навлажнена кърпа или обикновен препарат за поддържане на мебели, за да почистите повърхностите.
- HR** Upute za njegu: Za čišćenje površina upotrijebiti jednu lako navlaženu krpu i trgovačko uobičajeno sredstvo za njegu namještaja.
- LT** Rekomendacija priežiūrai: Paviršius valykite drėgna pašluoste arba parduotuvėse įsigytomis baldų priežiūros priemonėmis.
- RU** Рекомендации по уходу: для очистки поверхностей используйте слегка влажную тряпку или обычное средство по уходу за мебелью.
- CN** 保养说明: 清洁表面只需用稍微潮湿的布或普通的家具清洁剂即可。
- HU** Ápolás: A felületek tisztításához enyhén nedves ruhát vagy a kereskedelemben kapható bútörápoló terméket használjon.
- AR** إرشاد للعناية: يرجى من أجل تنظيف الأسطح استخدام منديل رطب بعض الشيء أو استخدام إحدى مواد تنظيف الأثاث المتوفرة في الأسواق التجارية.

Beschläge

Fittings / Raccords / Hulpstukken /
Фурнитура / 配件 / Vasalatok

PAIDI Möbel GmbH
Hauptstraße 87
97840 Hafenlohr
Germany









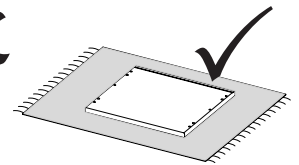
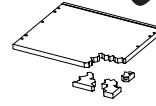
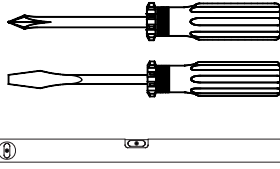
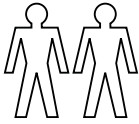

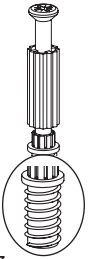

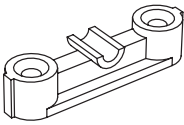





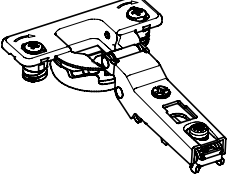

Kinderwelten

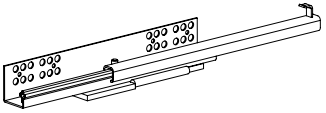
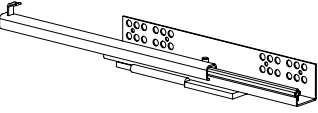

ca. 1,5h

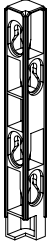

A  4x 681 0757	B  8x 681 0759	C  4x 681 0886	D  3,5 x 20 8x 681 4888	E  4x 681 5561	F  3,5 x 25 10x 681 4900	G  ø8 x 30 4x 681 0700	H  4,0 x 40 4x 681 4907	I  4 x 35 4x 681 5001
J  6x 681 2793	K  4x 681 8126	L  4x 681 8137	M  12x 681 0350	N  ø8 x 45 1x 681 0402	O  2x 681 3318			
P  2x 681 3319		Q  6,3 x 14 8x 681 5097	R  8x 681 2498	S  3,0 x 20 5x 681 4914	T Griffstange Länge: 212mm 4x 681 8458	U  4,0 x 40 8x 681 4911		
X  Farbton Sandbeige 6x 683 0112	Z  6x 681 2552	ZA₁₃₂  4x 681 9105						

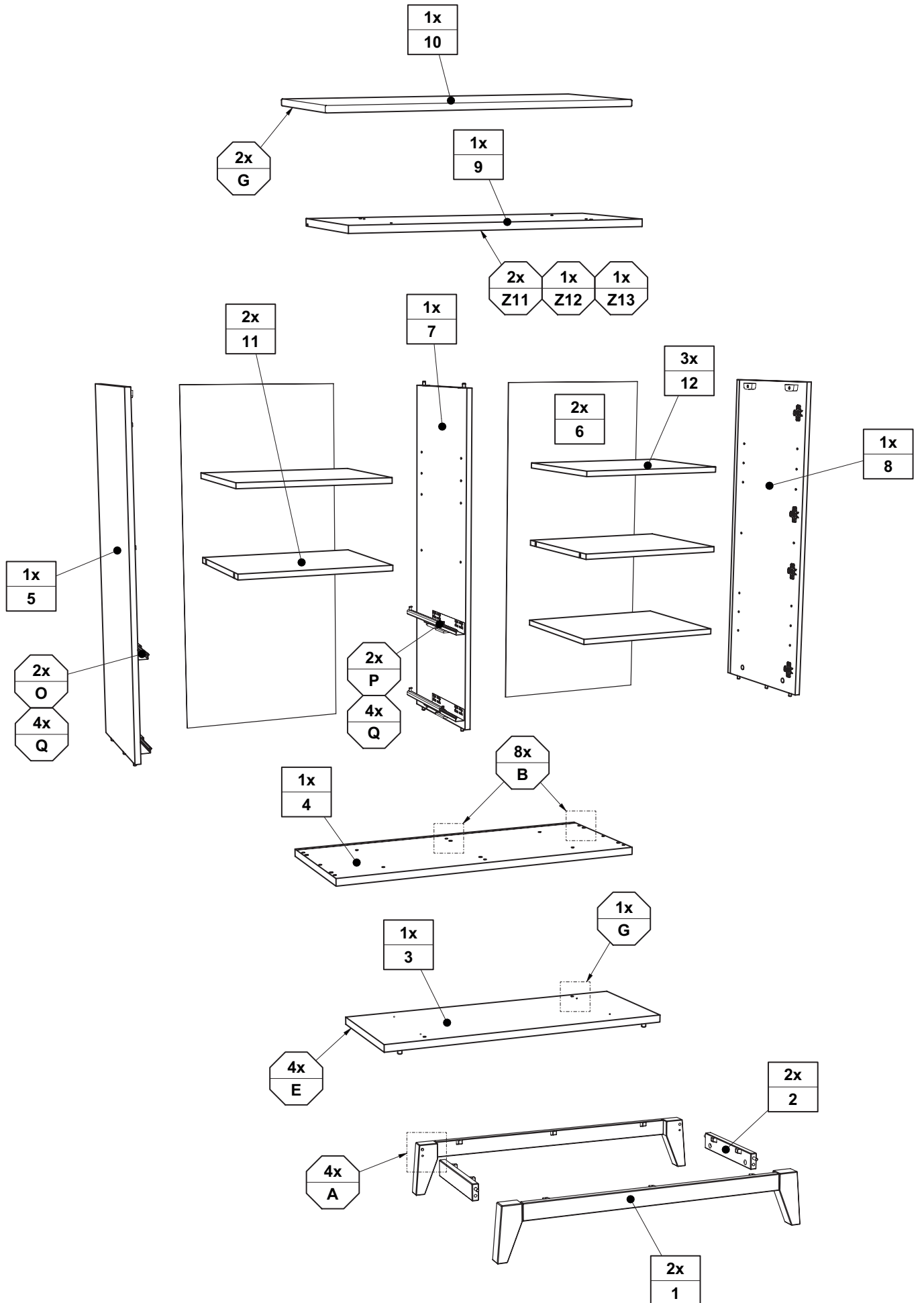

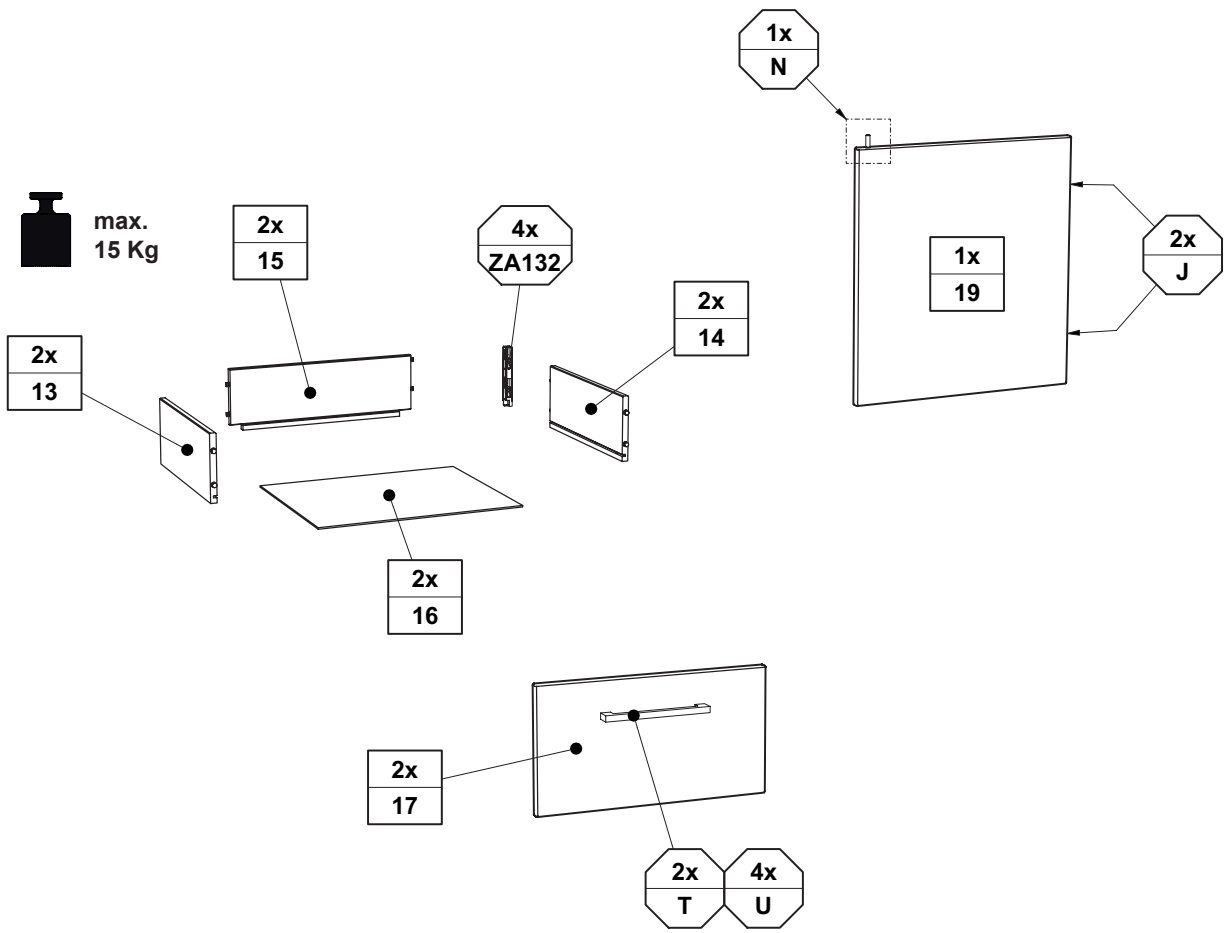
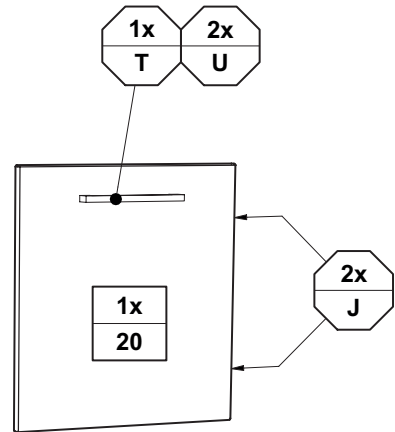
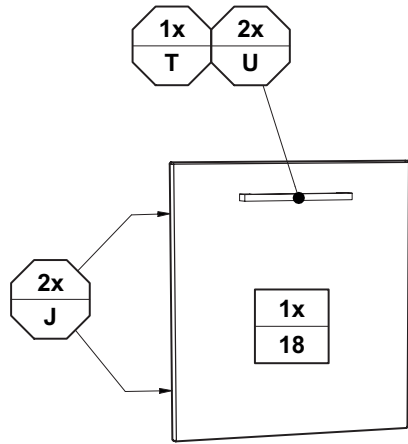

V1

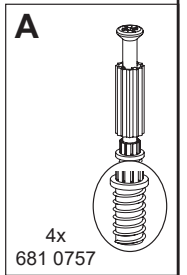
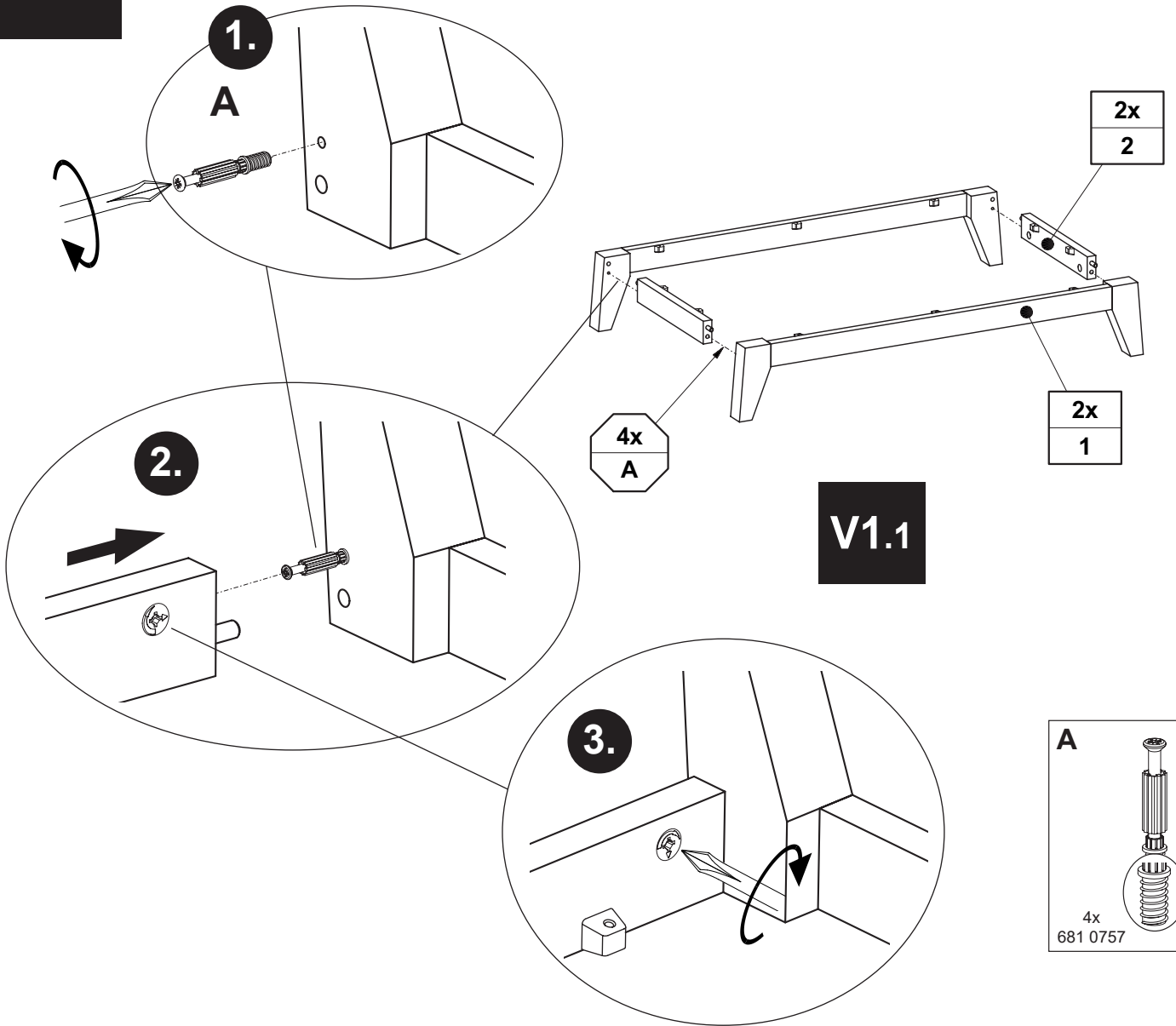

V1.2

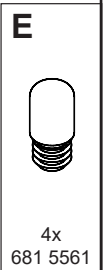
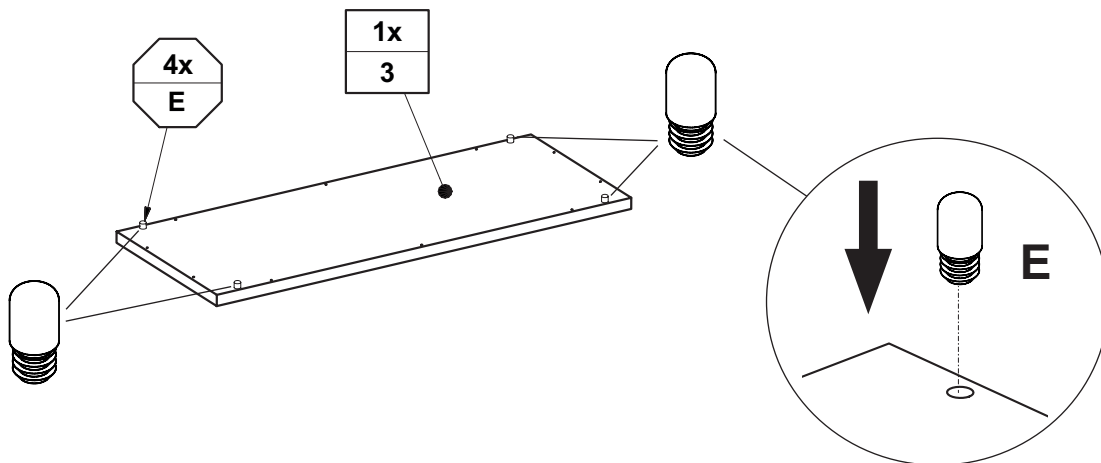

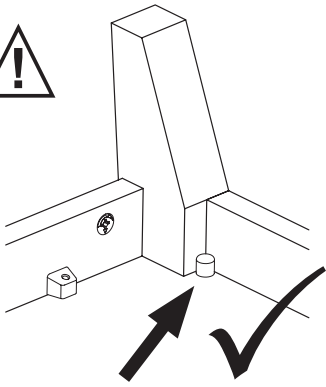

V1.3

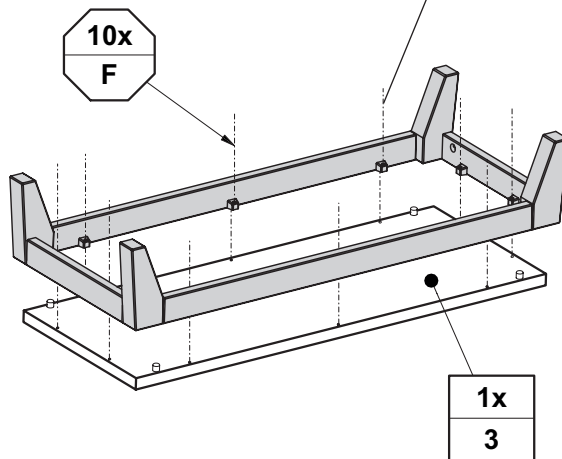
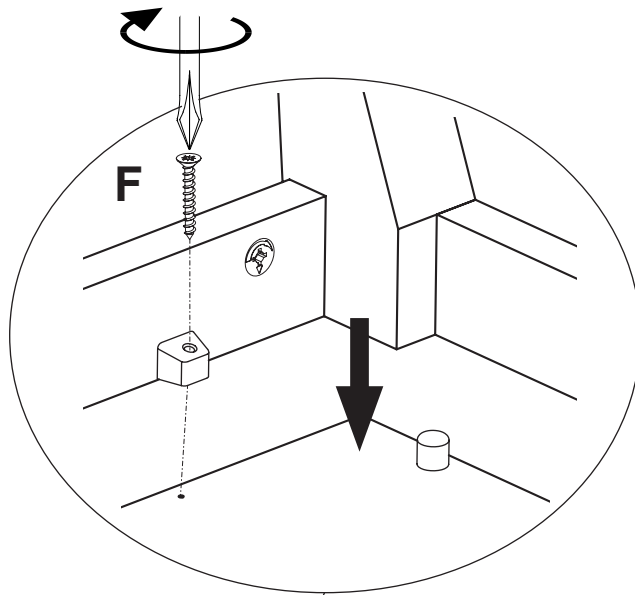

F



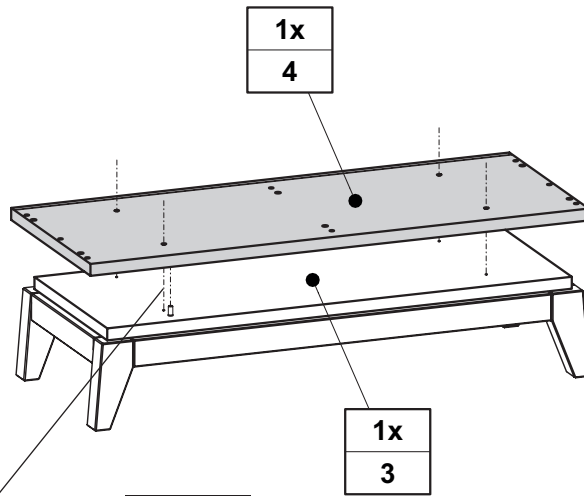

3,5 x 25
10x
681 4900

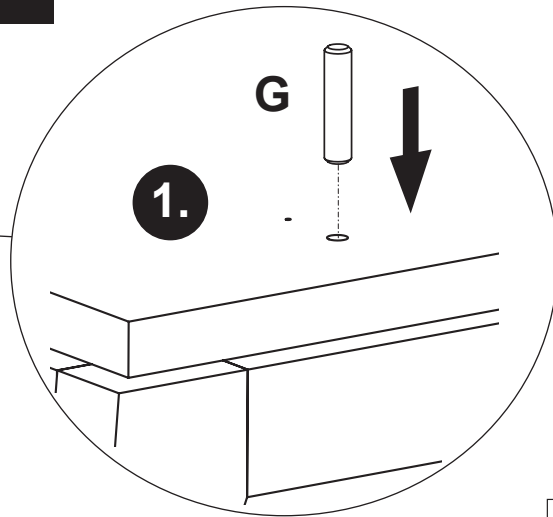
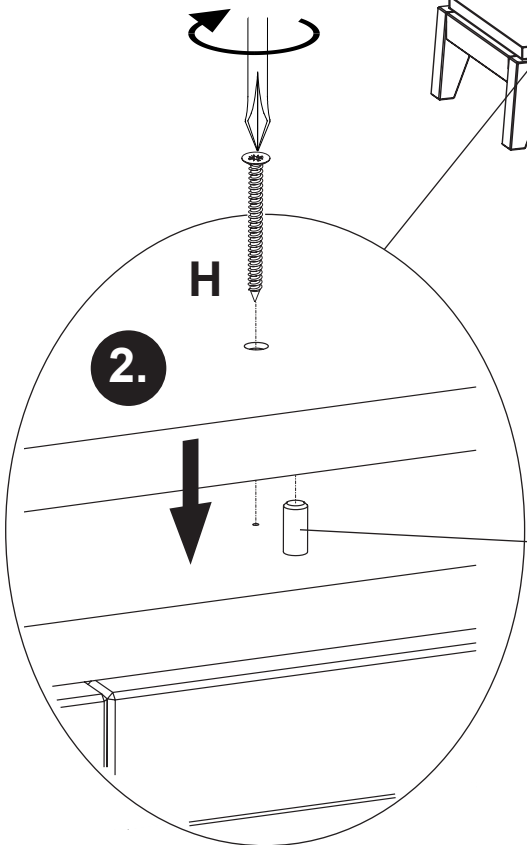

V1.4



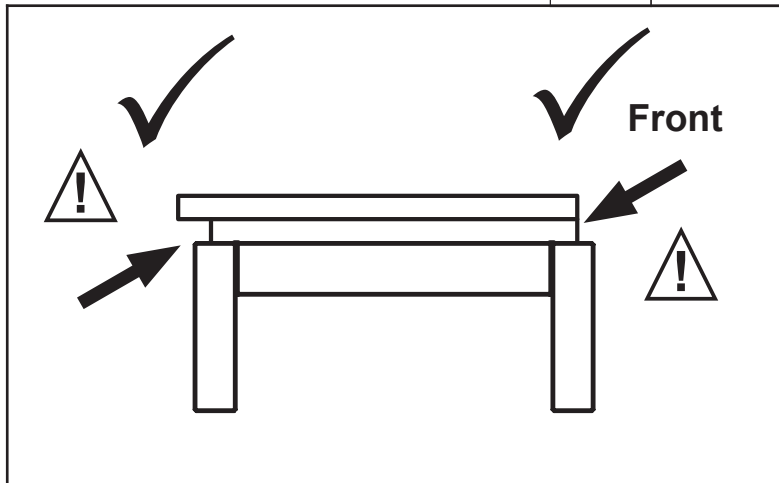

G	H
	
ø8 x 30	4,0 x 40
2x	4x
681 0700	681 4907

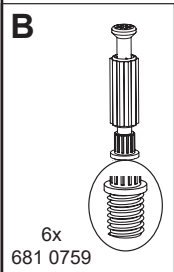
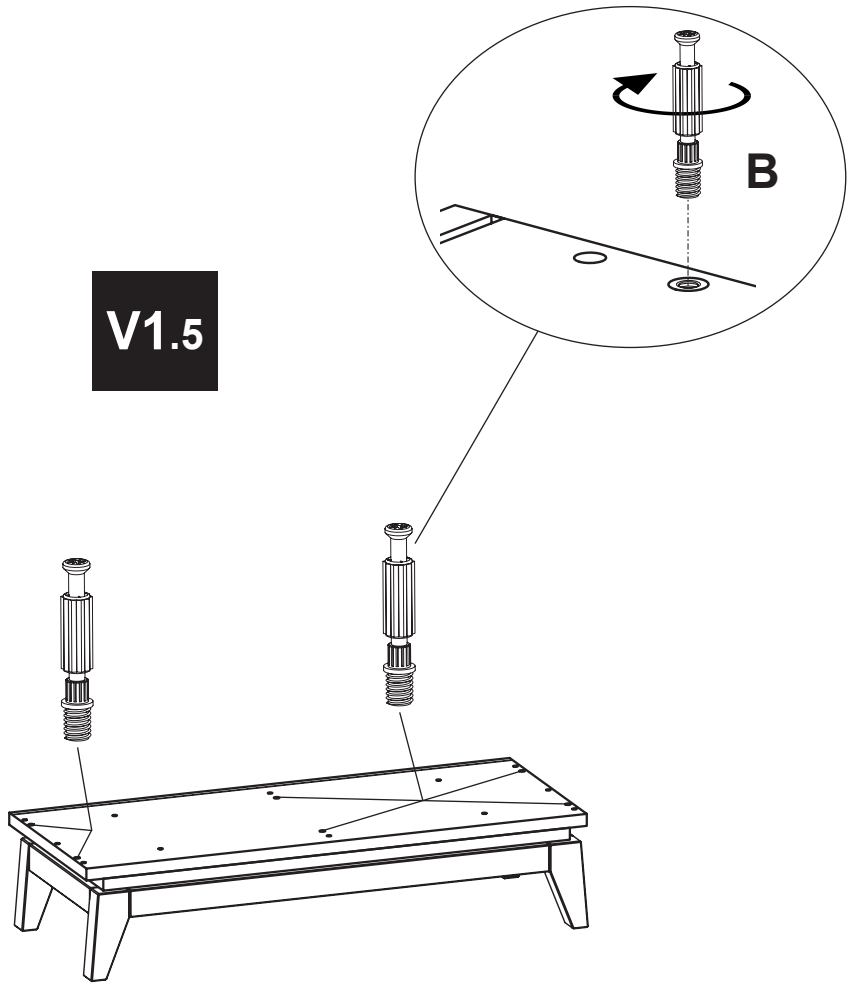

V1.5

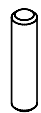

V2

G	I
	
ø8 x 30 2x 681 0700	4 x 35 4x 681 5001

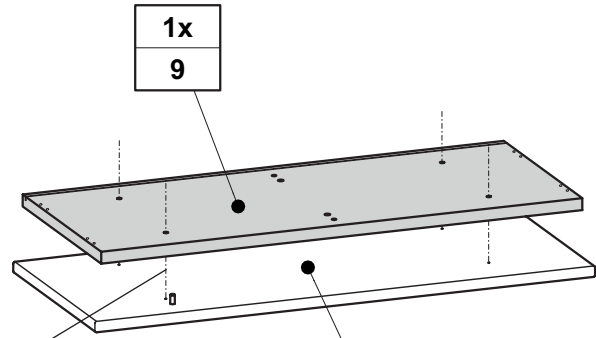

V2.1

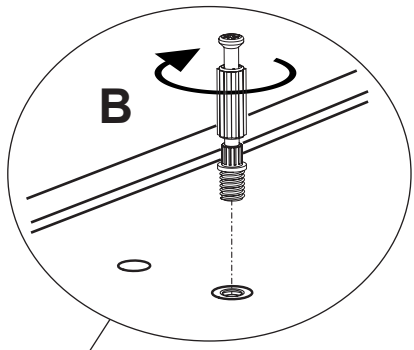
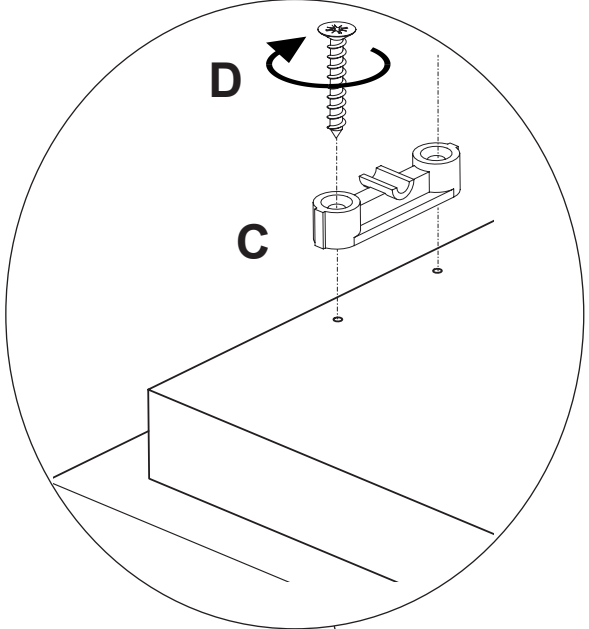
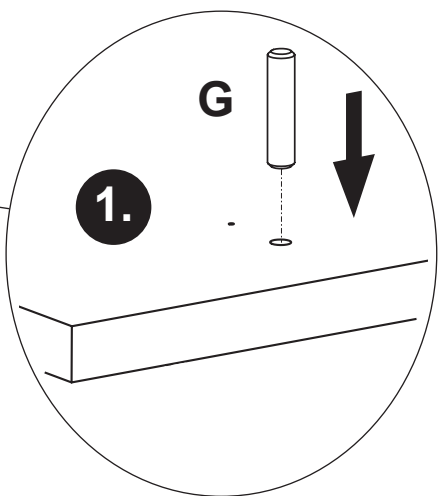
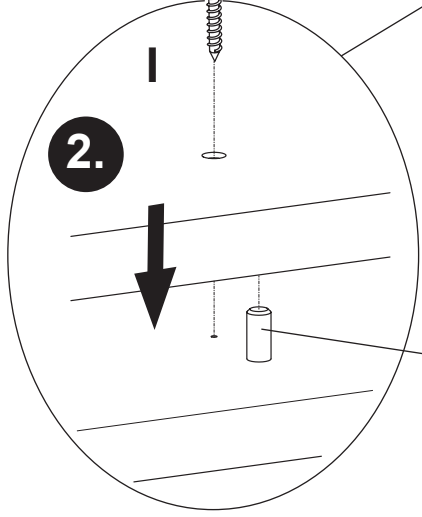

V2.2

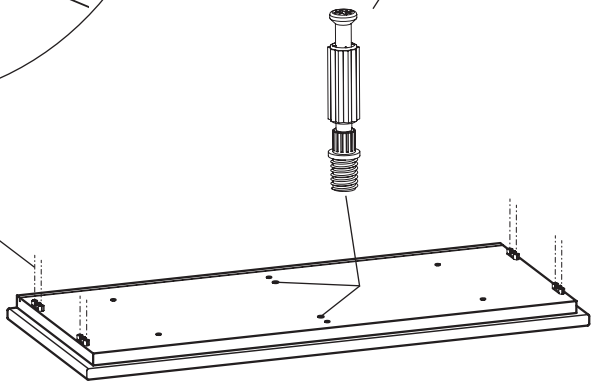

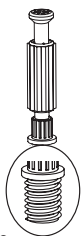
B

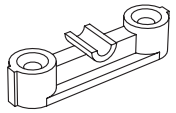
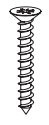
2x 681 0759

C	D
	
4x 681 0886	3,5 x 20 8x 681 4888

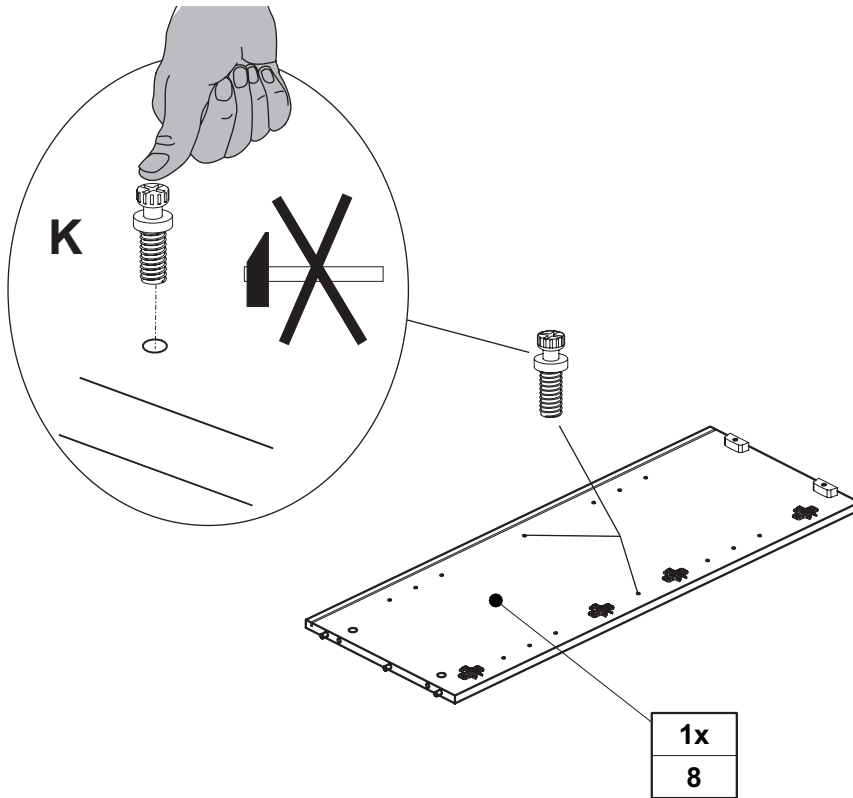
V3



K



2x
681 8126

V4

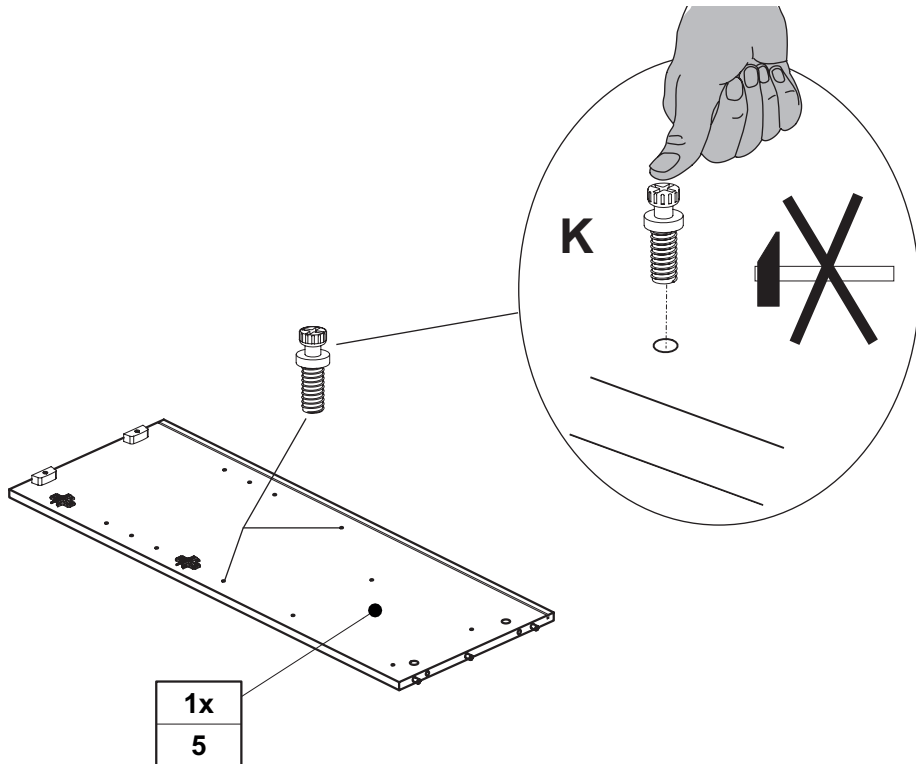

K



2x
681 8126

Seite 11 von 25

PK-Nr. 3429 Stand 07/2024

V5

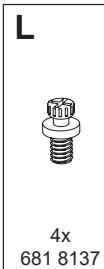
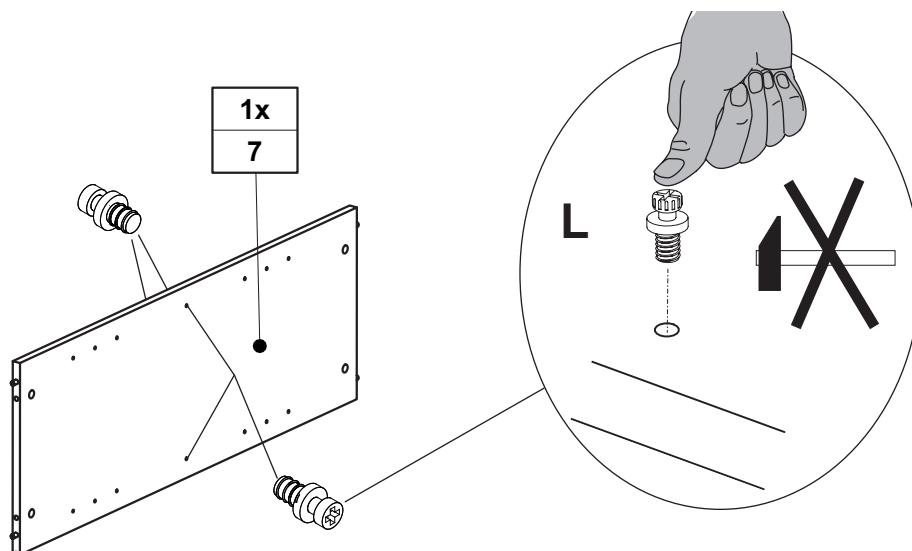

V6

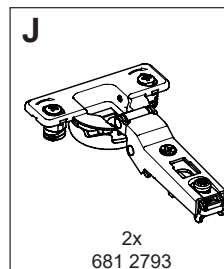
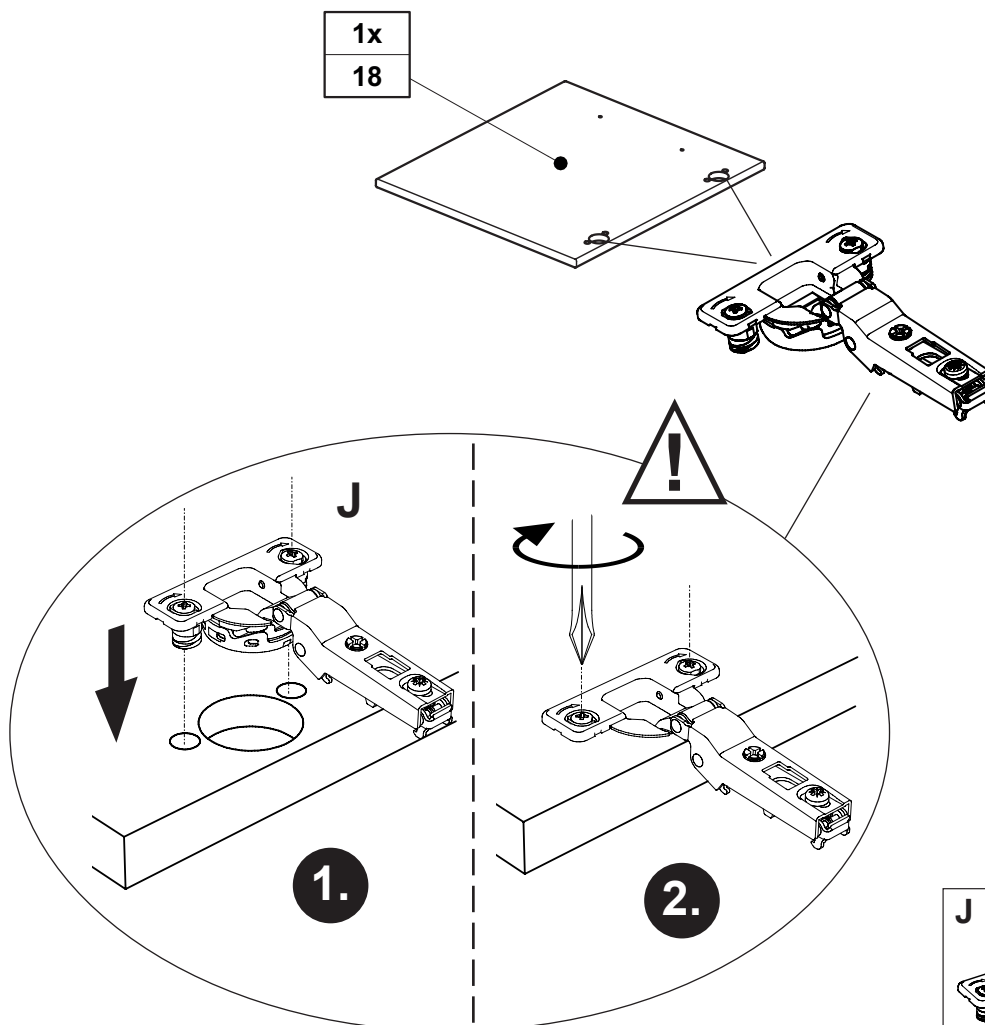

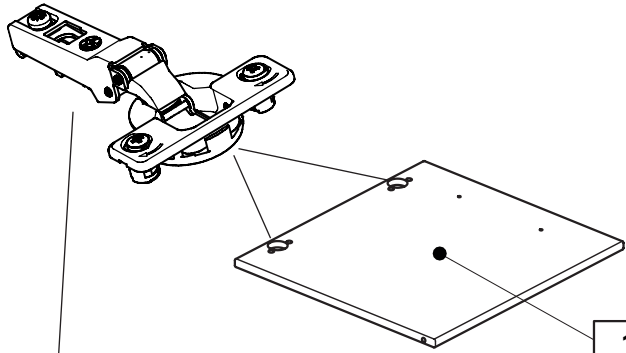

1x
20

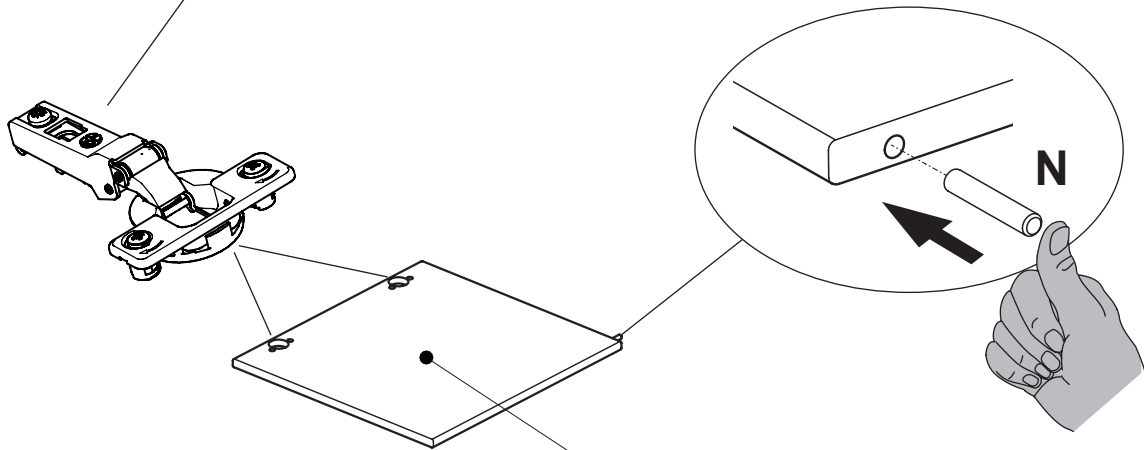
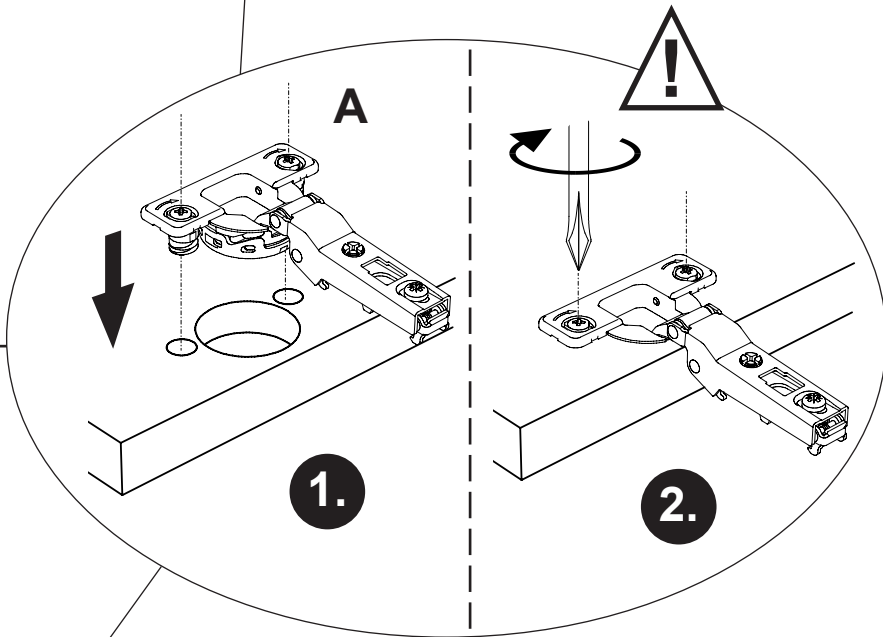
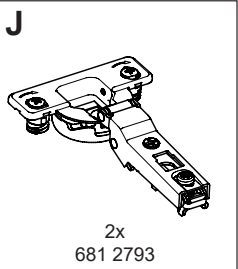

1x
19

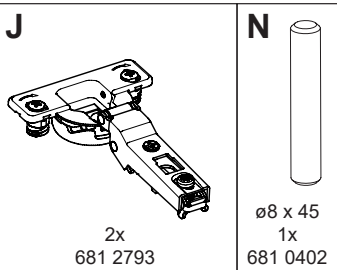

V9

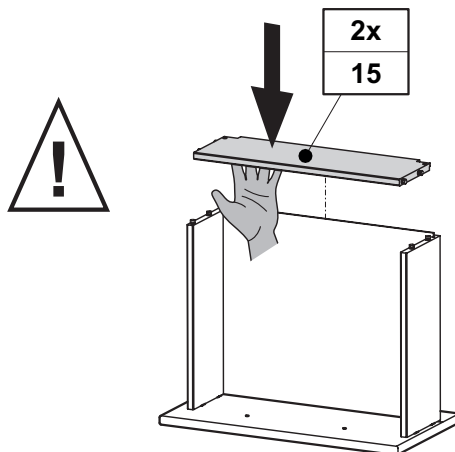
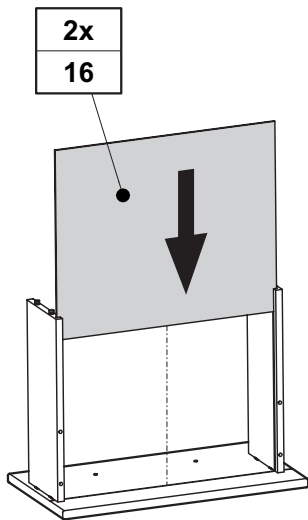
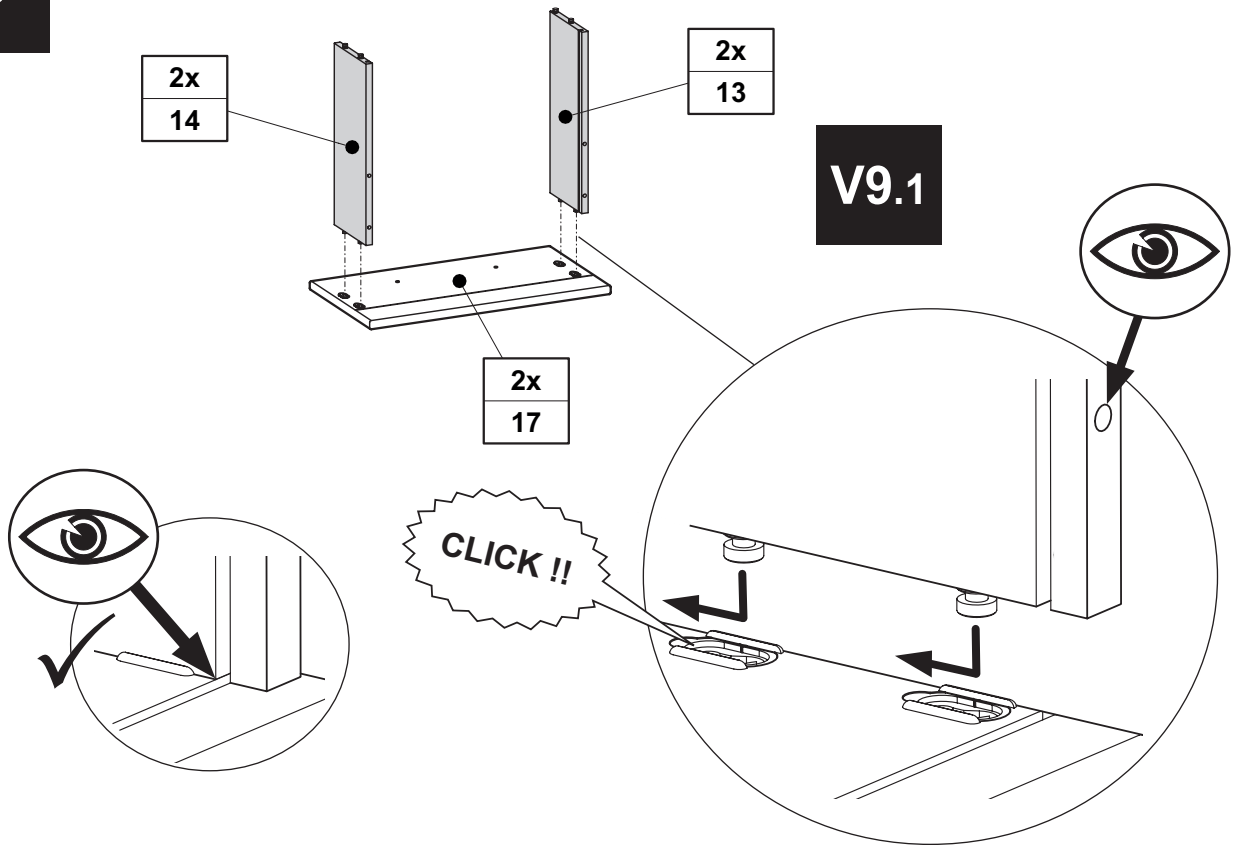

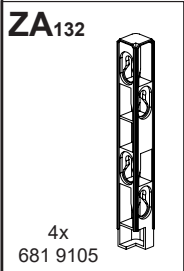
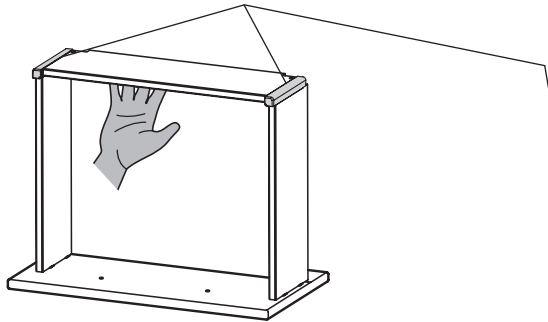

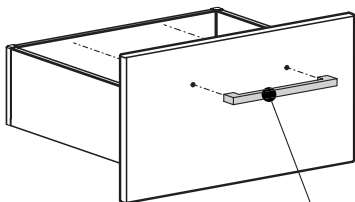
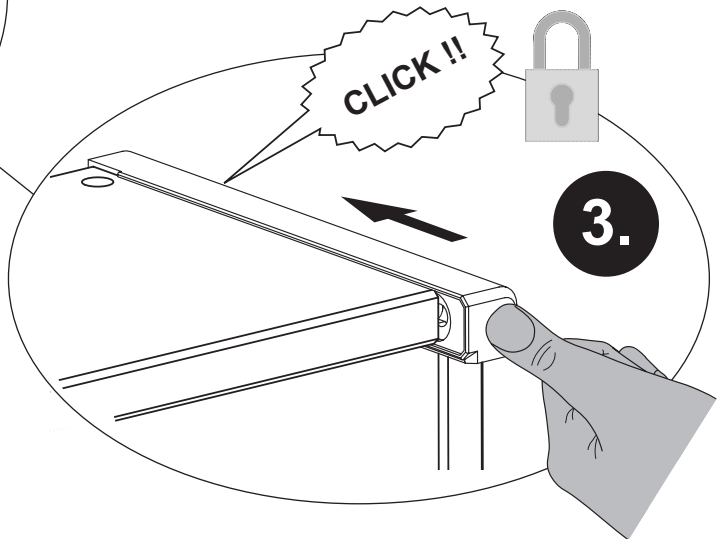
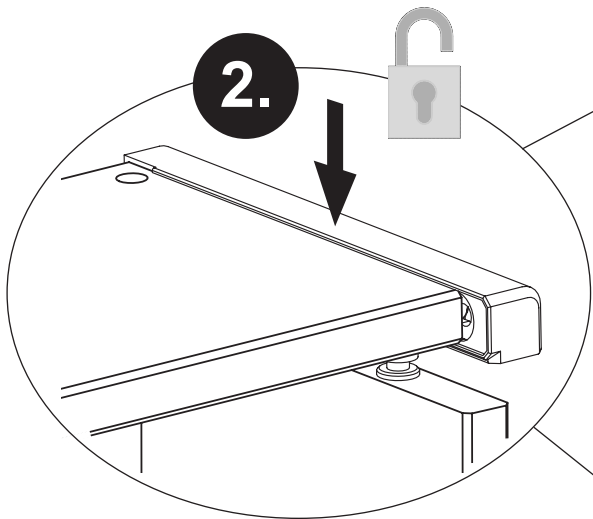
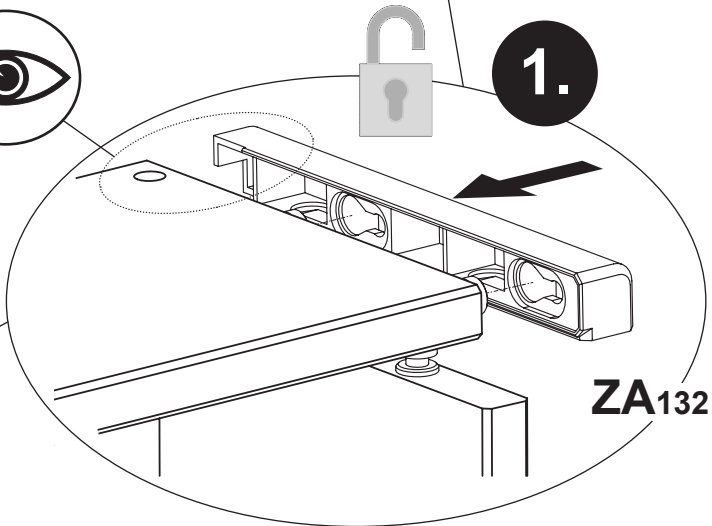

V9.4

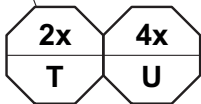

V9.5



T	U
Griffstange	
Länge: 212mm	
2x 681 8458	4,0 x 40 4x 681 4911

M1

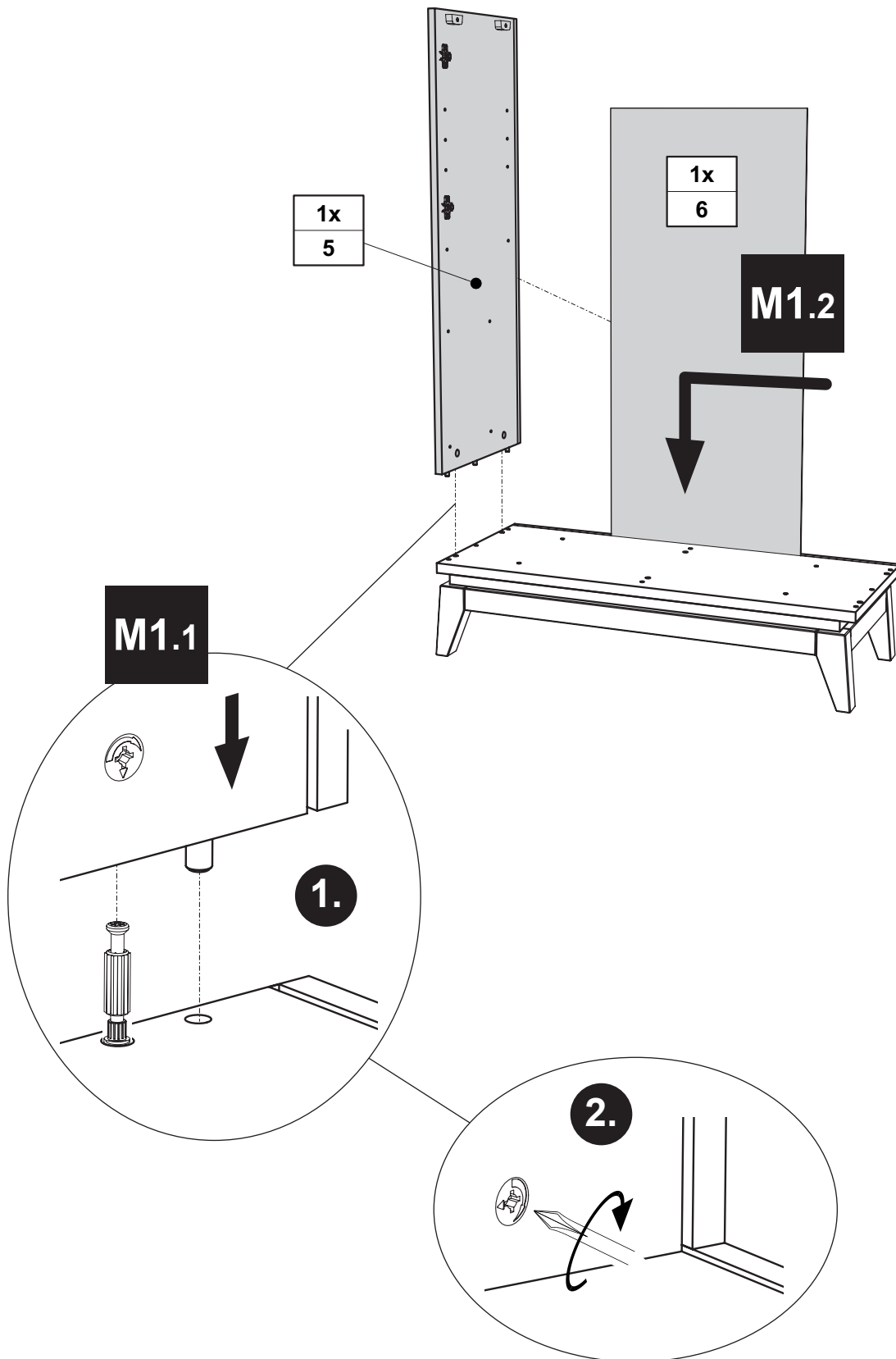

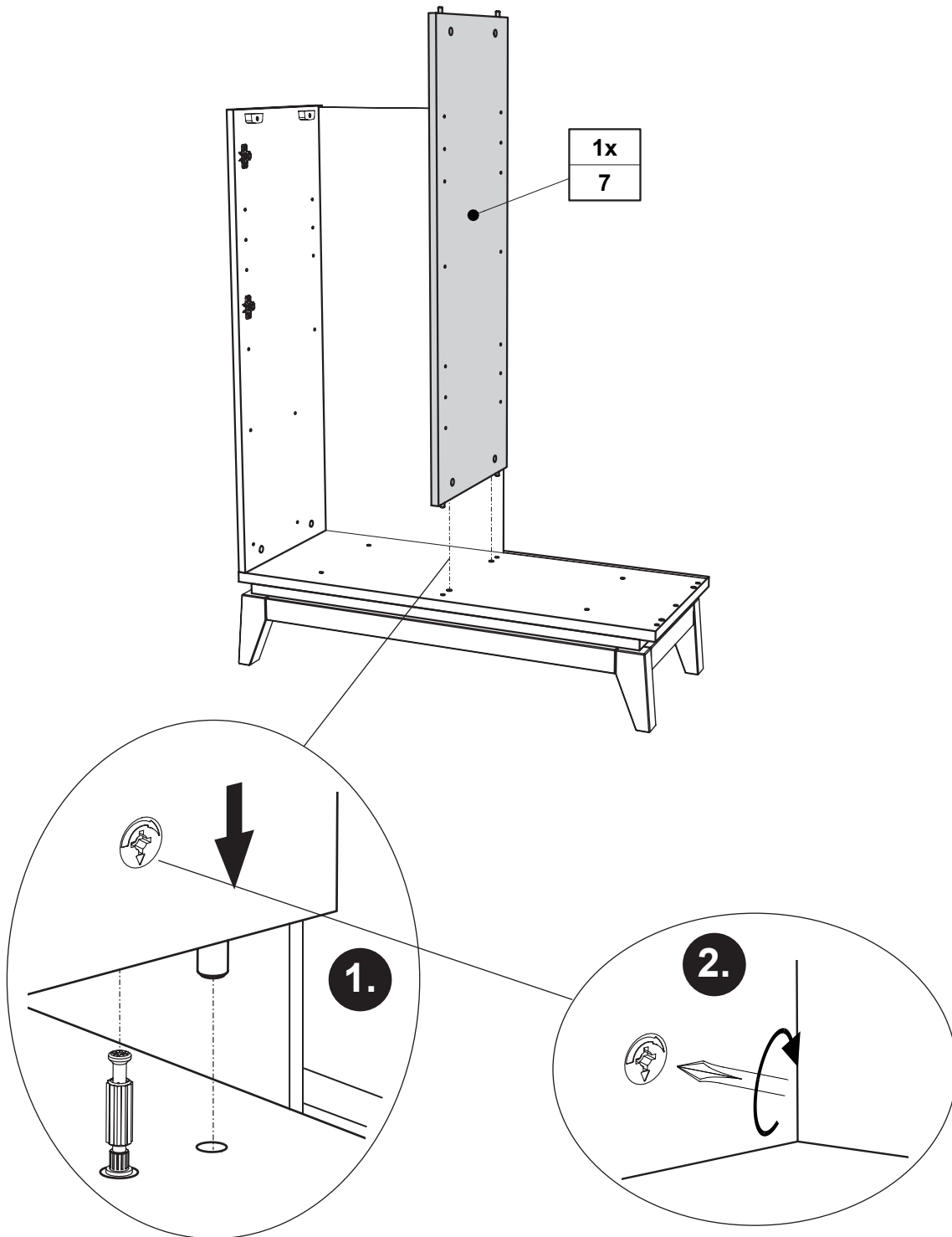

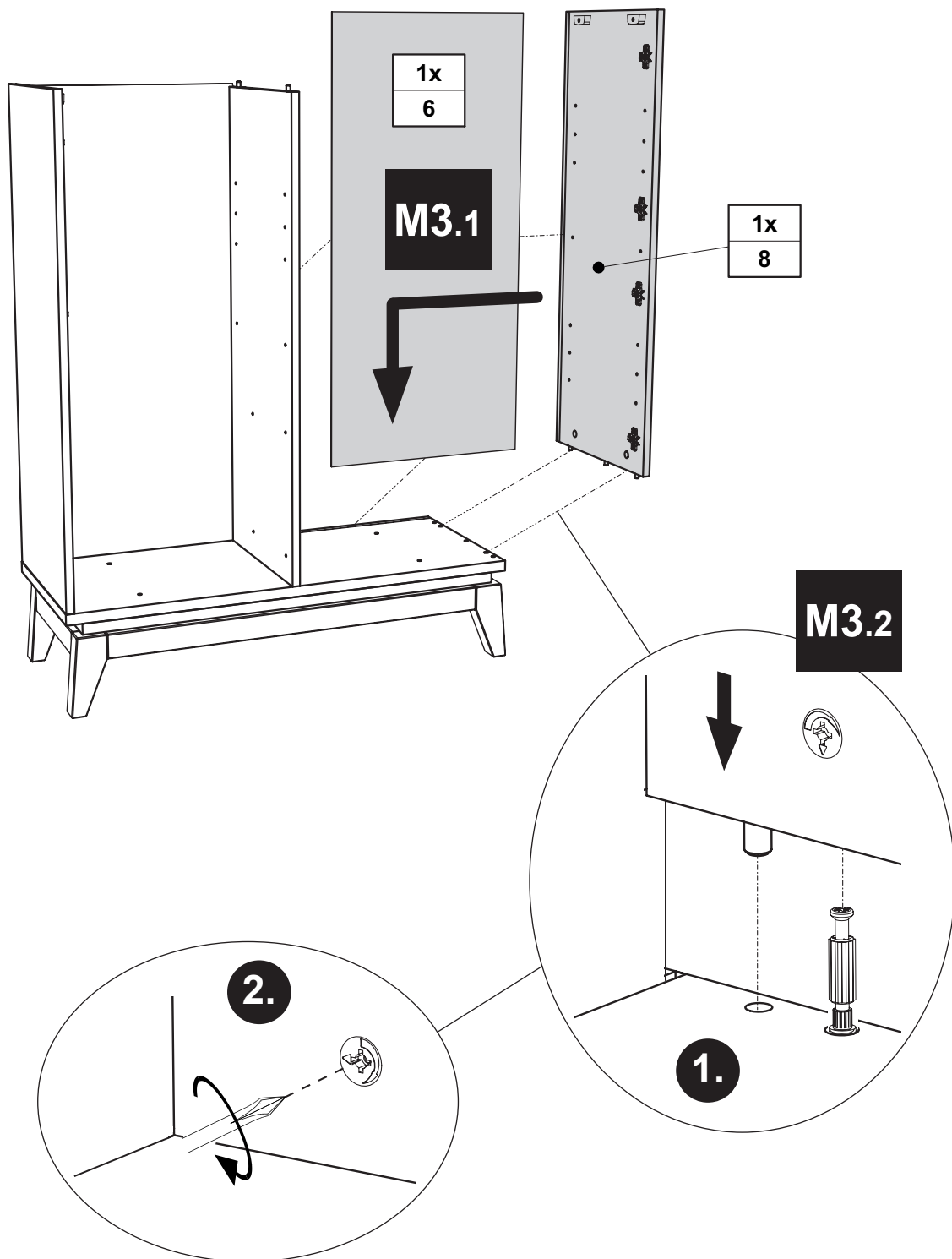

M3

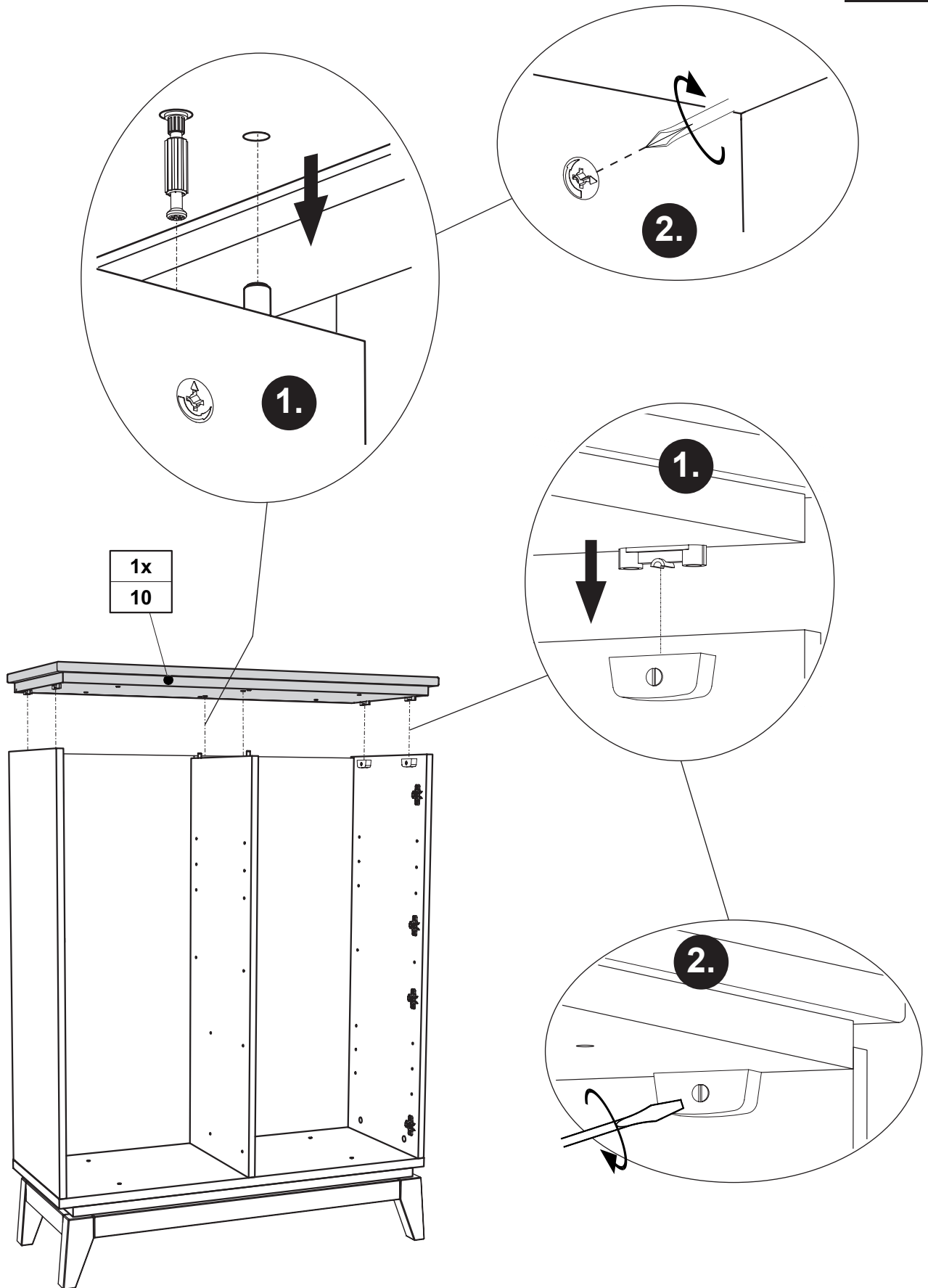

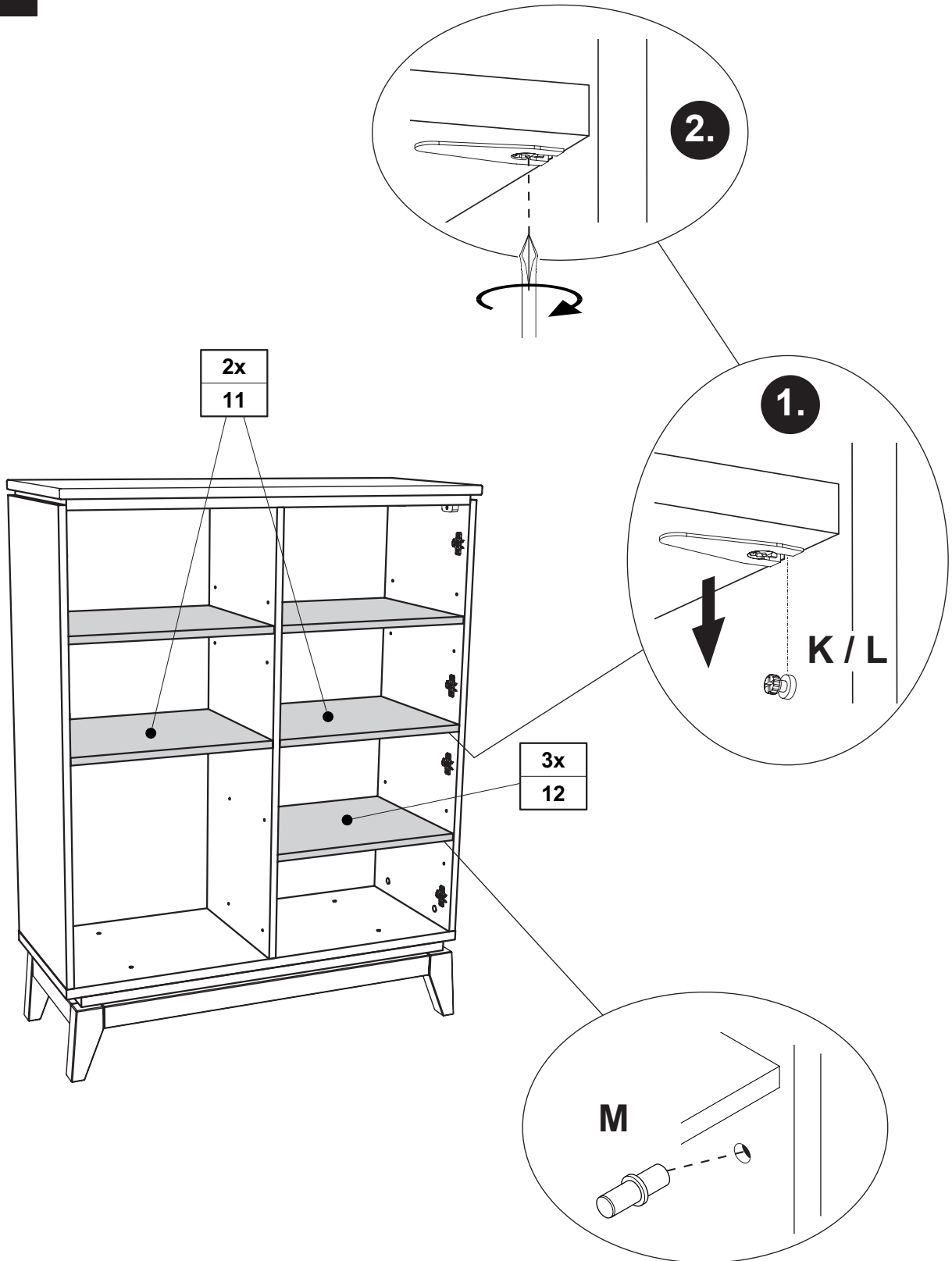

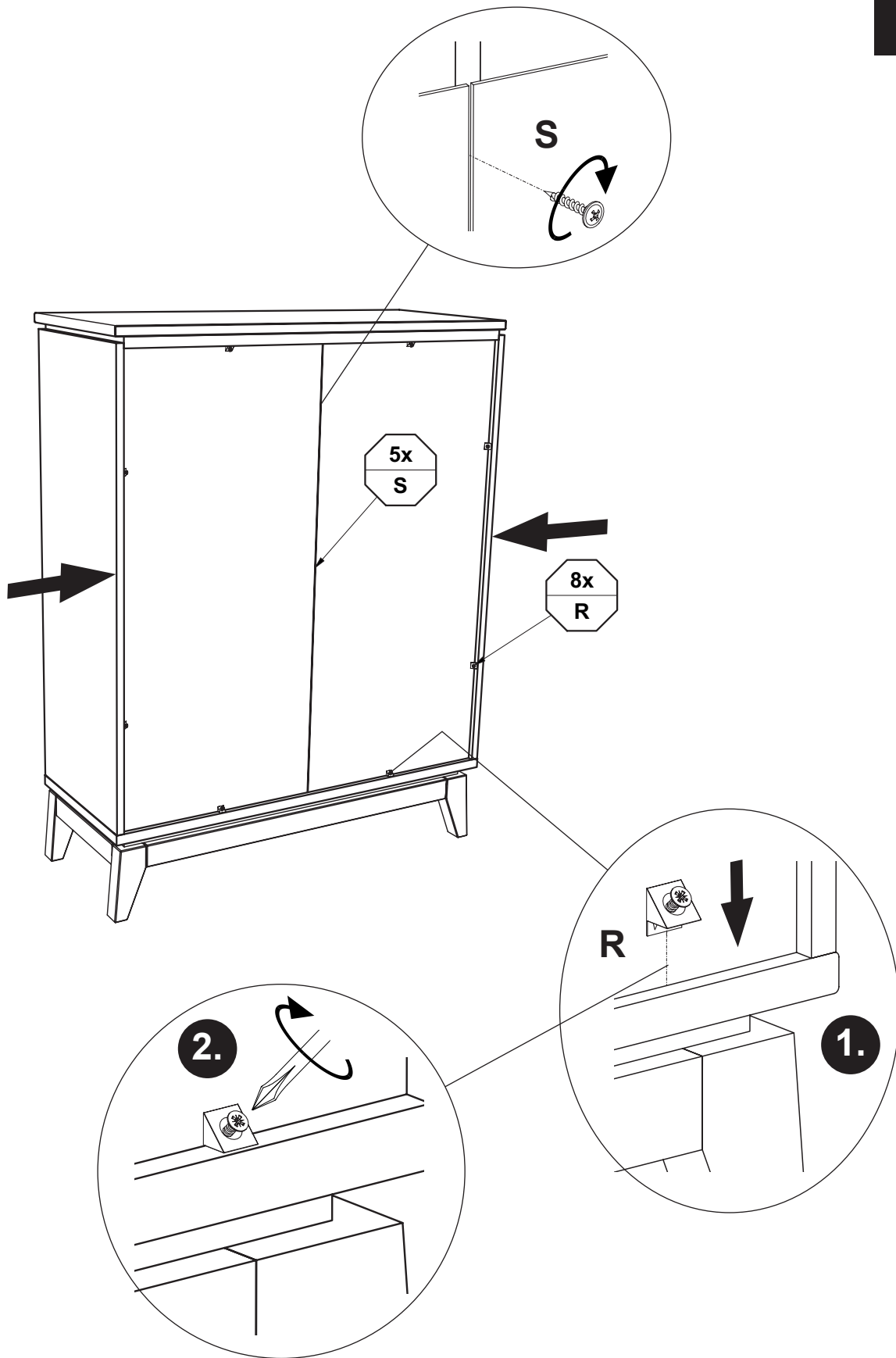

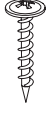

R	S
	
8x 681 2498	3,0 x 20 5x 681 4914

Kippsicherung !!

siehe PK-Nr. 2800

Tilt protection !
 Dispositif anti-basculement !
 Kantelbeveiliging !
 Защита от опрокидывания !
 防倾倒装置 !

2x Z11 1x Z12 1x Z13

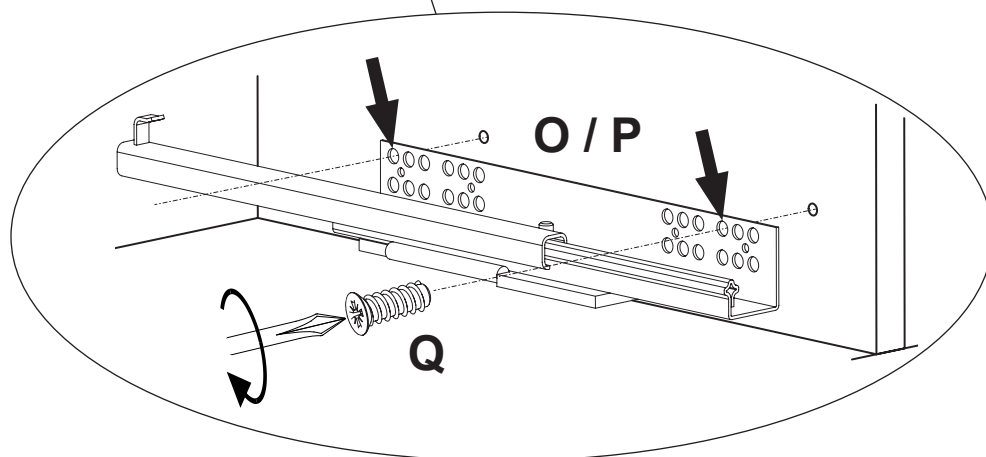
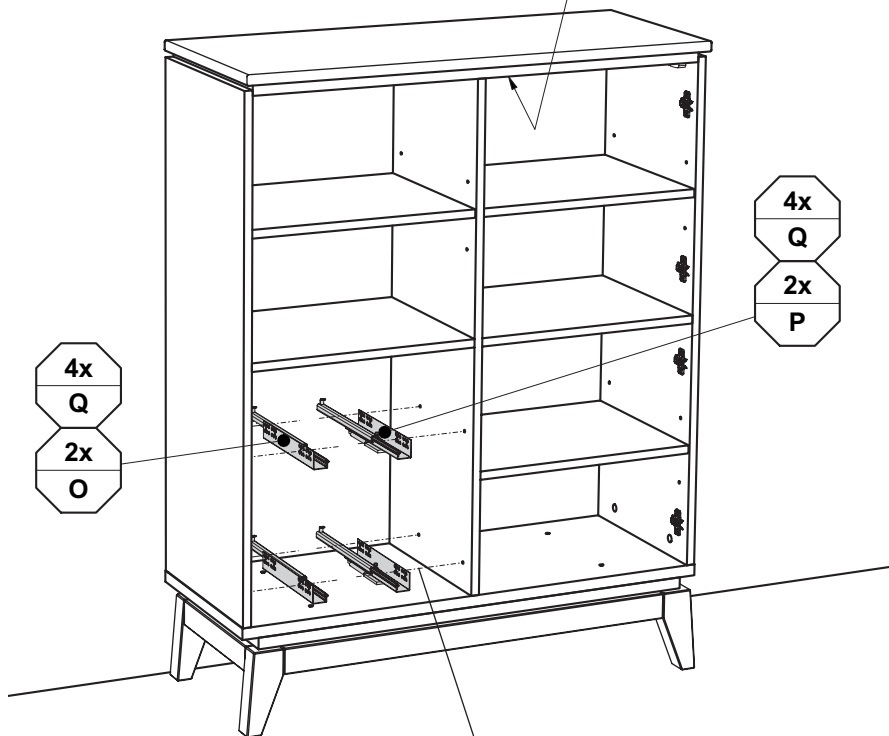

<p>O</p> <p>2x 681 3318</p>	<p>P</p> <p>2x 681 3319</p>	<p>Q</p> <p>6,3 x 14 8x 681 5097</p>
--	--	---

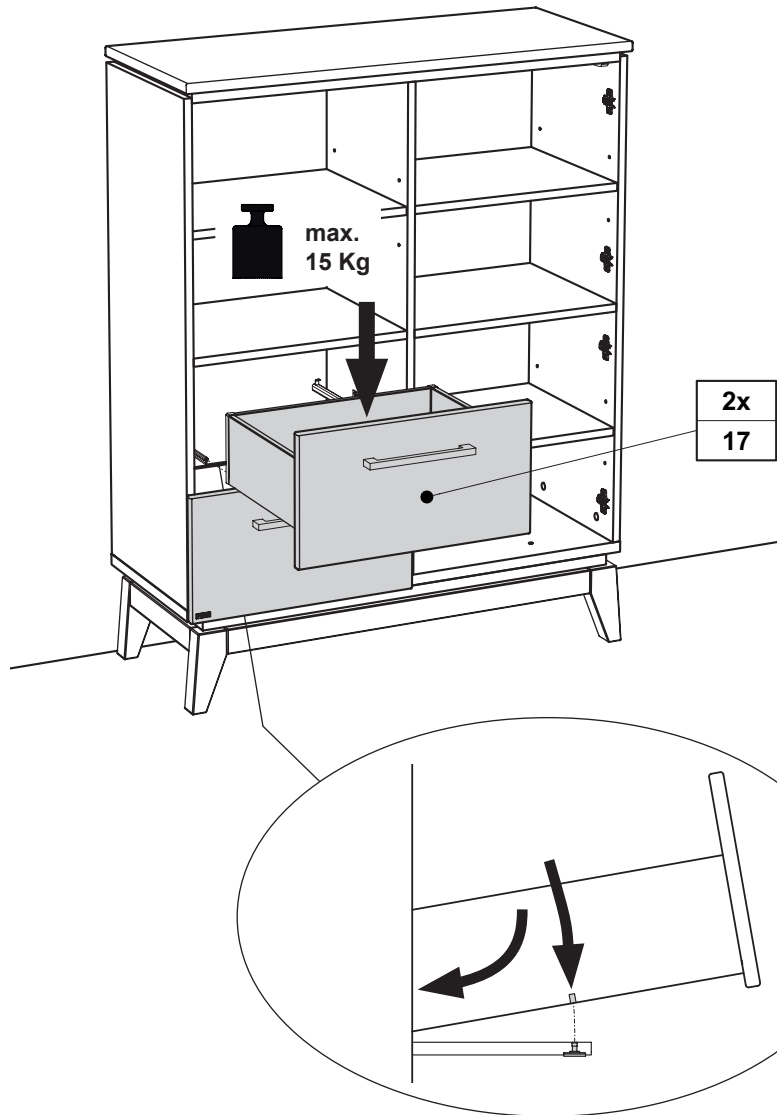

Justierung der Schubkästen

Adjustment of drawers / Réglage des tiroirs / Afstelling van de lades /
Регулировка выдвижных ящиков / 抽屜的調整

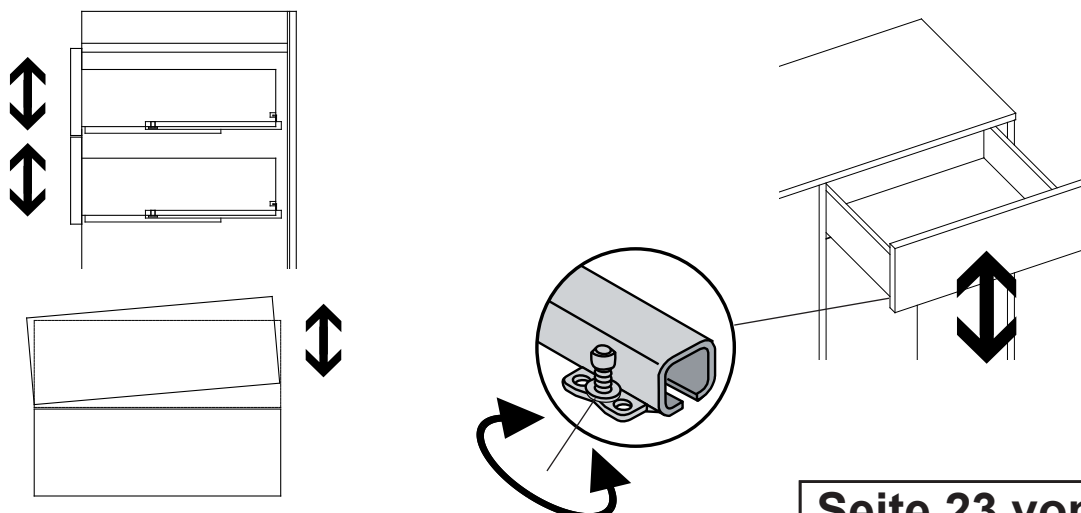

M9

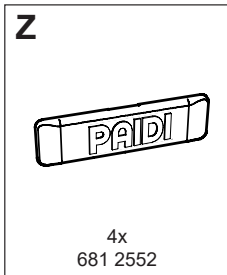
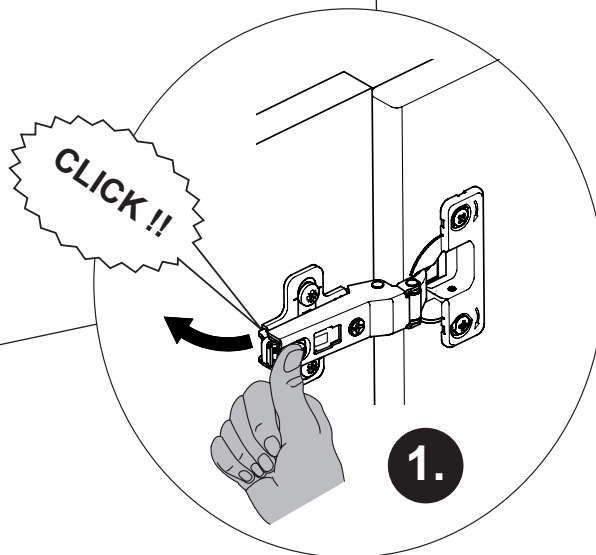
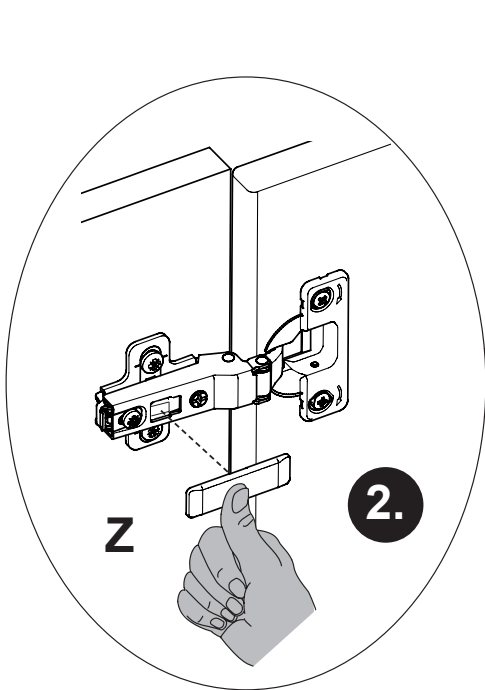
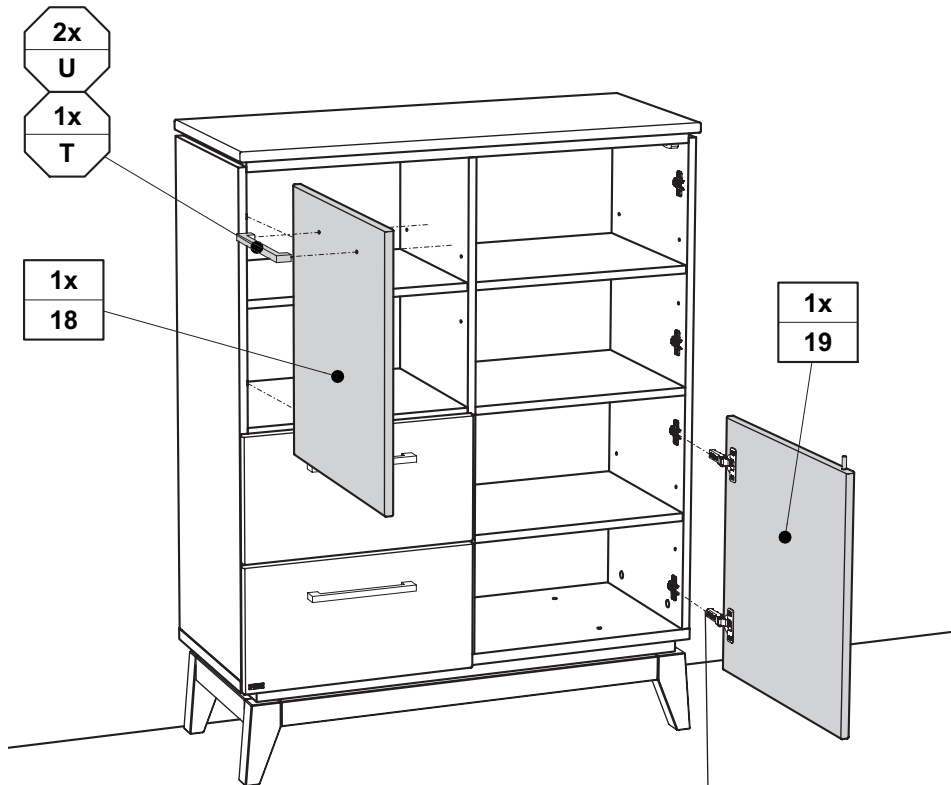

4x
681 2552

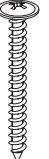
T	U
Griffstange	
Länge: 212mm	
1x 681 8458	4,0 x 40 2x 681 4911

Demontage der Türen
 Disassembly of doors
 Démontage des portes
 Demontage van de deuren
 Демонтаж дверок
 拆卸门

Justierung der Türen
 Adjustment of doors
 Réglage des portes
 Afstelling van de deuren
 Регулировка дверок
 门的调整

